



# MODEL G8120 STRAIGHT HANDLE METAL SHEAR INSTRUCTION SHEET



<b>⚠ WARNING</b>	
	<b>EYE/EAR INJURY HAZARD!</b> Wear safety glasses and hearing protection during use of this tool!
	<b>INJURY HAZARD!</b> Always disconnect tool from air to prevent unexpected operation during service!
	<b>DO NOT EXCEED 120 PSI!</b> Personal injury could occur.
	<b>CUT HAZARD!</b> Keep hands and fingers away from scissor action of blades. Serious cuts will occur!



Figure 1. Model G8120.

## Maintenance

Metal shear **MUST** have 3-4 drops of oil directly dropped into the air fitting before each use as shown in **Figure 2**.

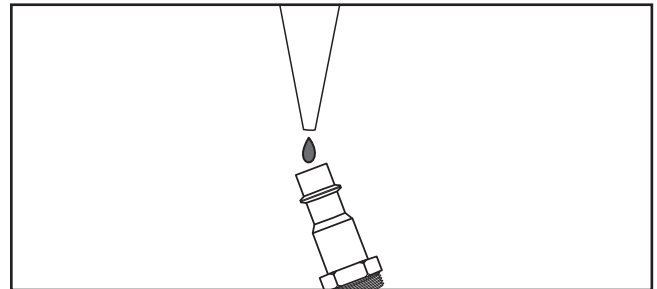

Figure 2. Lubricating directly into air fitting.

## Introduction

This straight handle metal shear is highly maneuverable for working into tight spots. It cuts sheet steel up to 3/64" thick and sheet aluminum up to 1/16" thick. Width of cut is 7/32". The no-load speed is 2500 strokes per minute and average air consumption is 6 CFM.

## Inventory

- A. Metal Shear ..... 1
- B. Hex Wrench 4mm ..... 1

## Operation

Install a 1/4" NPT quick connect air fitting into the end of the metal shear. Lubricate before use with pneumatic tool oil, then connect metal shear to your regulated air source. Pull the handle lever to operate.

If blade sharpening is ever needed, remove the three lock screws (#23) with the 4mm hex wrench to remove the blades & spacers (#24–27). Take the blades to a qualified sharpening and grinding service, then reinstall.

*If you need help with your new pneumatic tool, call our Tech Support at: (570) 546-9663.*

# G8120 Parts Breakdown and List

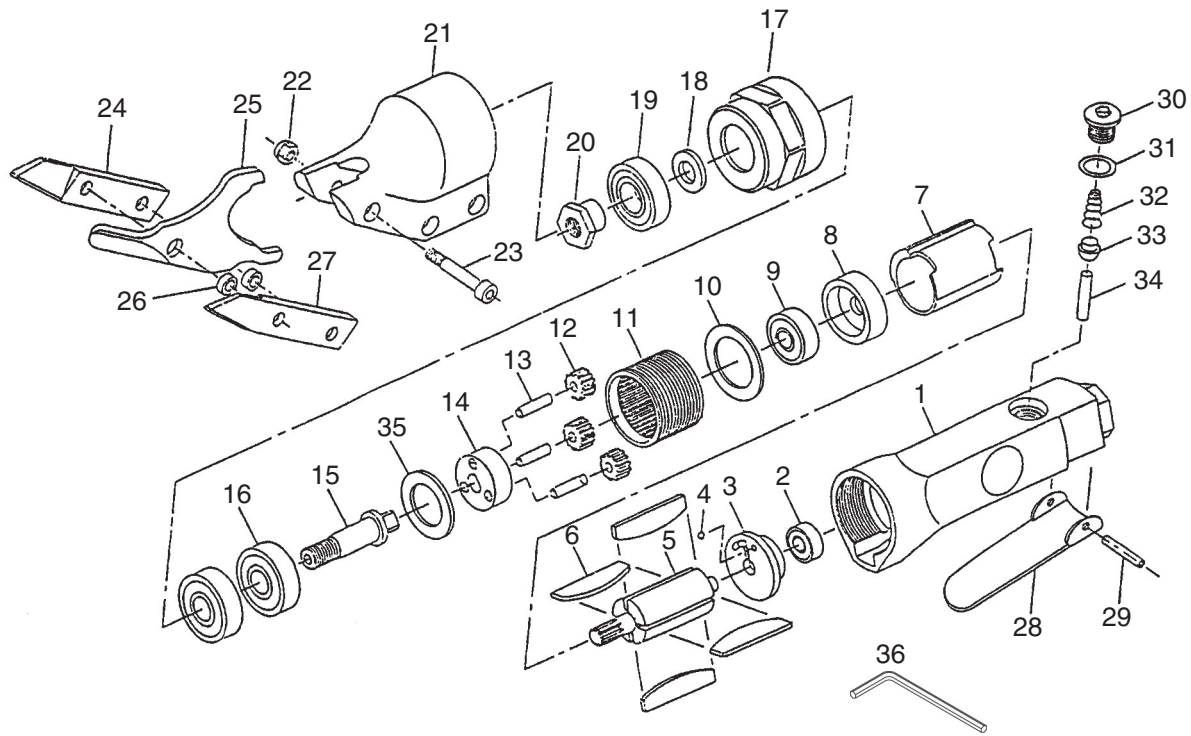

REF	PART #	DESCRIPTION
1	P8120001	HOUSING
2	P8120002	REAR BEARING
3	P8120003	REAR PLATE
4	P8120004	STEEL BALL
5	P8120005	ROTOR
6	P8120006	ROTOR BLADE
7	P8120007	CYLINDER
8	P8120008	FRONT PLATE
9	P8120009	FRONT BEARING
10	P8120010	WASHER
11	P8120011	THREAD RING GEAR
12	P8120012	IDLER GEAR
13	P8120013	IDLER GEAR PIN
14	P8120014	IDLER GEAR PLATE
15	P8120015	SHAFT
16	P8120016	BEARING
17	P8120017	CLAMP NUT
18	P8120018	WASHER

REF	PART #	DESCRIPTION
19	P608	BEARING
20	P8120020	ECCENTRIC NUT
21	P8120021	CUTTER HOUSING
22	P8120022	LOCK NUT
23	P8120023	LOCK SCREW
24	P8120024	LEFT BLADE
25	P8120025	CENTER BLADE
26	P8120026	SPACER
27	P8120027	RIGHT BLADE
28	P8120028	LEVER
29	P8120029	PIN
30	P8120030	VALVE PLUG
31	P8120031	O-RING
32	P8120032	SPRING
33	P8120033	VALVE STEM BUSHING
34	P8120034	VALVE STEM
35	P8120035	WASHER
36	PAW04M	HEX WRENCH 4MM